

The
FREQ-MITE
A PIC-Based Morse Frequency Counter

Thanks for purchasing the Small Wonder Labs / 4SQRP Freq-Mite, a Morse-readout frequency-annunciating device. The Freq-Mite is user programmable, so it's readily adaptable to the IFs in most QRP rigs and is ideal for field operation.

Specifications:

Maximum Count Frequency:	32.767 MHz
Accuracy:	+/- 1.5 KHz to 25 MHz +/- 2 KHz at 32 MHz
Input Sensitivity (typical)	100 mV p-p (to 5 MHz) 600 mV p-p max (to 32 MHz)
Output:	800 Hz Tone, 13/26 WPM selectable 3- or 4-digit format (see 'programming') 5V p-p, AC-coupled (CMOS logic)

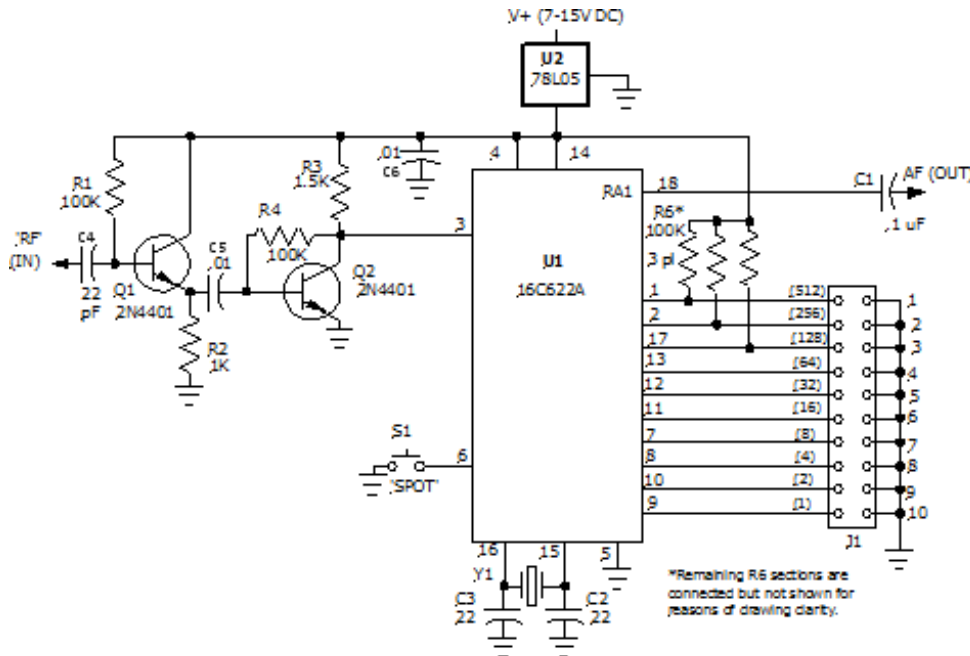

You'll find an antistatic envelope containing the following parts:

- | | |
|--|--|
| 1- Printed Circuit board, 'SWL 11/02', '4SQRP 11/2013' | 3- 100K resistor (brn/blk/ylw/gld) (R1, R4, Audio) |
| 1- 18-pin IC Socket | 1- resistor network, 5x100K (R6) |
| 1- 16C622A IC, preprogrammed (U1) | 1- 78L05 IC (U2) |
| 1- 4.096 MHz crystal, 20 pF load (Y1) | 2- 2N4401 transistor (Q1, Q2) |
| 3- 22 pF NPO disk cap (C2, C3, RF-IN) | 5- 6" lengths insulated wire |
| 2- .01 uF disk cap | 1- #4-40 machine screw, 1/4" |
| 1-.1 uF monolithic cap (Audio) | 1- angle bracket, threaded #4-40 |
| 1- 1K resistor (brn/blk/red/gld) (R2) | 9- shorting jumpers |
| 1- 1.5K resistor (brn/grn/red/gld) (R3) | 1- pushbutton switch (S1) |
| | 1- 20-pin header (or 2- 10-pin header strips) |

PICTORIAL:

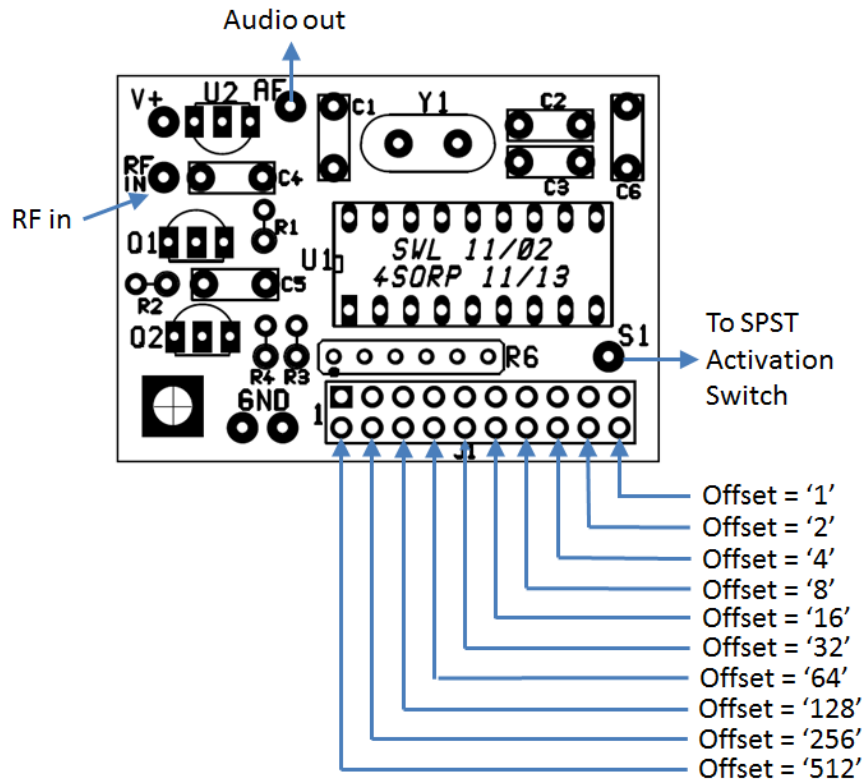

- *Install all parts on the side of the board with white lettering. Solder only on the reverse (underside).*

Assembly Instructions:

- 1) Install and solder the 6-pin resistor network. The end with the dot must be oriented on the left end of the component as shown in the pictorial above.
- 2) Install the IC socket, 'notched' end to the left. Solder down just 2 diagonally-opposite corners. Reheat the joints while pressing the socket down with a fingertip from the backside of the board. This ensures the socket is installed flush with the board surface. Solder all remaining IC socket pins.
- 3) Install the dual-row jumper strip (or two 10-pin strips). Make sure the strip(s) are seated firmly on the circuit board.

- 4) Install the 4.096 MHz crystal. Elevate the crystal approximately 1/16" above the PC board so the body of the crystal doesn't form a short between the two pins. Some folks like to make a small washer from a piece of paper or cardboard.
- 5) Install all remaining small components as shown. Note the installation orientations of Q1, Q2 and U2- these must be installed as shown in the pictorial. *Resistors are bent in 'hairpin' fashion for upright installation.*
- 6) Add the following external wiring using the supplied hookup wire:

Signal Name	Connect to:
AF OUT	Piezo annunciator ¹ , headphones/ spkr ² or receiver AF injection point ³ (see below)
Ground	Ground return
V+	7-15V VDC
RF In	Input from RF Source- /use R17 lead for SW+ series
S1	Normally-open pushbutton switch (return goes to ground)

- 1) For **Piezo annunciator**, use an 'external-drive' type such as Radio Shack #273-073. Short C1 with a wire jumper.
- 2) For **direct headphone/speaker** use, short C1.
- 3) For **injection into a receiver or transceiver**, a sample of the Freq-Mite output is injected into the receiver audio chain. This point is typically just prior to the receiver's audio output stage. A large resistance (100k supplied) may be need in series to the audio stage to reduce the signal to acceptable levels. Results vary from rig to rig- a larger value of resistance decreases the level. *SW+ series injection point: R9 or R10 wire lead on top of board.*
- 5) (**Make sure the power supply is disconnected.**) Install the 18-pin IC in the IC socket- be sure the 'dot' or notch in the IC case faces to the left. This part is static-sensitive- if possible, ground yourself when installing this IC.
- 6) Mount the Freq-Mite inside the case with the angle bracket. Attach the angle bracket on the Freq-Mite with a 4-40 screw through the board and into the threaded angle bracket. Mount to the case by making a small hole for a 4-40 screw (about 1/8") and attach with the screw from the outside, through the case and into the threaded angle bracket attached to the Freq-Mite. The Freq-Mite is very light so one mounting bracket is sufficient to hold it.
- 7) Mount the activation switch (S1) at a convenient location on the transceiver case. Hole size is 5.2mm (about 7/32"). Insert switch from outside. Fasten with nut inside and then attach/solder the two wires to the Freq-Mite.

Programming:

The Freq-Mite may be programmed for use with most QRP transceivers. These transceivers generally use a superhet configuration, and the Freq-mite usually needs to be programmed with an offset corresponding to the rig's IF

Offset programming is by means of a row of jumper pins on J1- these are binary-weighted. The rightmost position, when jumpered, yields an offset of 1 KHz, the one adjacent to that- 2 KHz, the next one 4 KHz, and so on.

Transceiver (3-digit) use:

The offset code is set equal to the 3-digit value of the IF in Kilohertz.

Example: A transceiver's IF is 8.192 MHz. *Discard the '8 MHz' portion of this number and what's left is .192 MHz (192 KHz). The offset is '192'. This offset is the sum of 128 + 64, so the arrangement of jumpers (left to right on J1) is '0011000000' where a '1' means a jumper is installed. A '0' means no jumper is installed.*

Programming example for inverted operation:

The White Mountain-75 SSB rig uses a 9830 KHz IF. The offset coding is therefore set to '830' and the pushbutton should be pressed after the 'I ?' prompt. For instance, for a local oscillator frequency of 6005, the IC measures (9830-6005) and outputs '825' to indicate an operating frequency of 3825 KHz

How do I know if I need to specify 'inverted' operation?

Inverted operation is necessary when increasing the local oscillator frequency decreases the operating frequency. If tuning upwards in operating frequencies yields decreasing results, try the 'inverted' operating mode.

The numbers are way off! How do I make it right?

Once you've chosen the normal/inverted mode correctly, the readout will track the desired result but at some fixed offset. If all else fails, adding or removing jumpers (cycling power each time) will bring the Freq-mite result into registration with the expected result.

General purpose (4 or 5-digit) use:

When you're homebrewing an oscillator or checking a transmitter's output on a 'stand-alone'* basis, it's useful to know the operating frequency complete with the 'MHz' digit(s). To enter this mode, add shorting jumpers to the seven (7) leftmost shorting locations on J1 and reapply power. This yields an offset code of '1016' (out of a maximum possible 1023 with all jumpers installed, and is recognized by the logic as an invalid offset. The logic then suppresses the offset portion of the calculation and outputs four or five digits. *Some examples:*

- An input signal frequency of 455 KHz yields a result of '0 4 5 5'
- An input signal frequency of 7.110 MHz yields a result of '7 1 1 0'
- An input signal frequency of 21.106 MHz yields a result of '2 1 1 0 6'

'Stand-alone': If you don't have convenient access to the local oscillator signal or it's above the 32.7 MHz count limit (this is true of many multiband rigs), a sample of the transmitter output (through a small-value capacitor 'T'ed off the coax can be measured. The Freq-Mite needs approximately 1/8th second of carrier (CW key-down, AM, FM, or 'Tune' mode) after S1 is pressed to get a good reading. In this event, you'll be using this General Purpose function.

Initialization:

Step 1:

Upon power-up, the Freq-Mite sends a Morse 'S ?'. If you press the pushbutton switch S1 within about 2 seconds, the Freq-mite performs all readout functions at 26 WPM. If you do not press the switch, the Freq-mite reads out at 13 WPM.

Step 2:

After that, if (and only if) you've programmed in a legitimate offset for transceiver (3-digit) mode, the Freq-Mite sends a Morse 'I ?'. If you press the pushbutton switch S1 within about 2 seconds, the Freq-mite calculates frequency using an inverted calculation. If you do not press the switch, the Freq-Mite reads out normally (i.e, without the inversion).

Initialization is complete when the Freq-Mite sends an 'AR' character.

"Initialization's all screwed up- how come?" Are you really using a normally-open switch for S1? If you're not sure, a normally-open switch will show a high resistance to ground until you press the switch. *This is tested with a multimeter on its 'ohms' scale and Freq-Mite power removed.*

Parts Problems? Befuddled?

If parts are missing from the kit or damaged, contact me for 'no-hassle' replacements. The best way to reach me is by e-mail. Please include your address when writing for parts- it'll speed things.

Russ Ramirez, K0WFS
7457 Lander Ave NE
Otsego, MN 55301

E-mail: freqmiteparts "at" gmail.com